

| Connection hoses and cables | |
|-----------------------------|---|
| Water hose: | ✓ |
| Waste water hose: | ✗ |
| Electric cable: | ✓ |

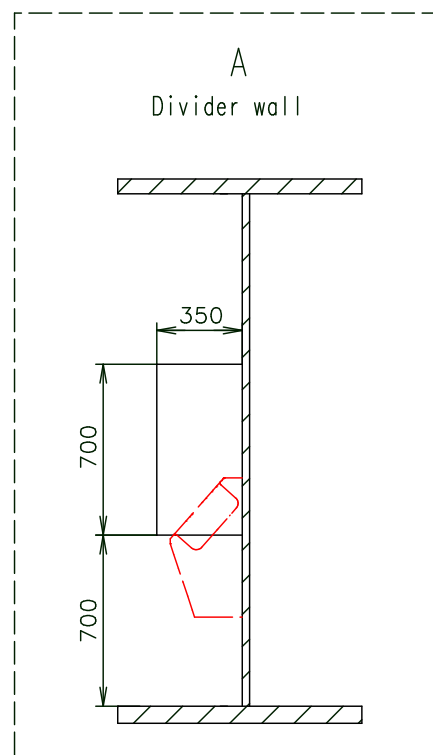
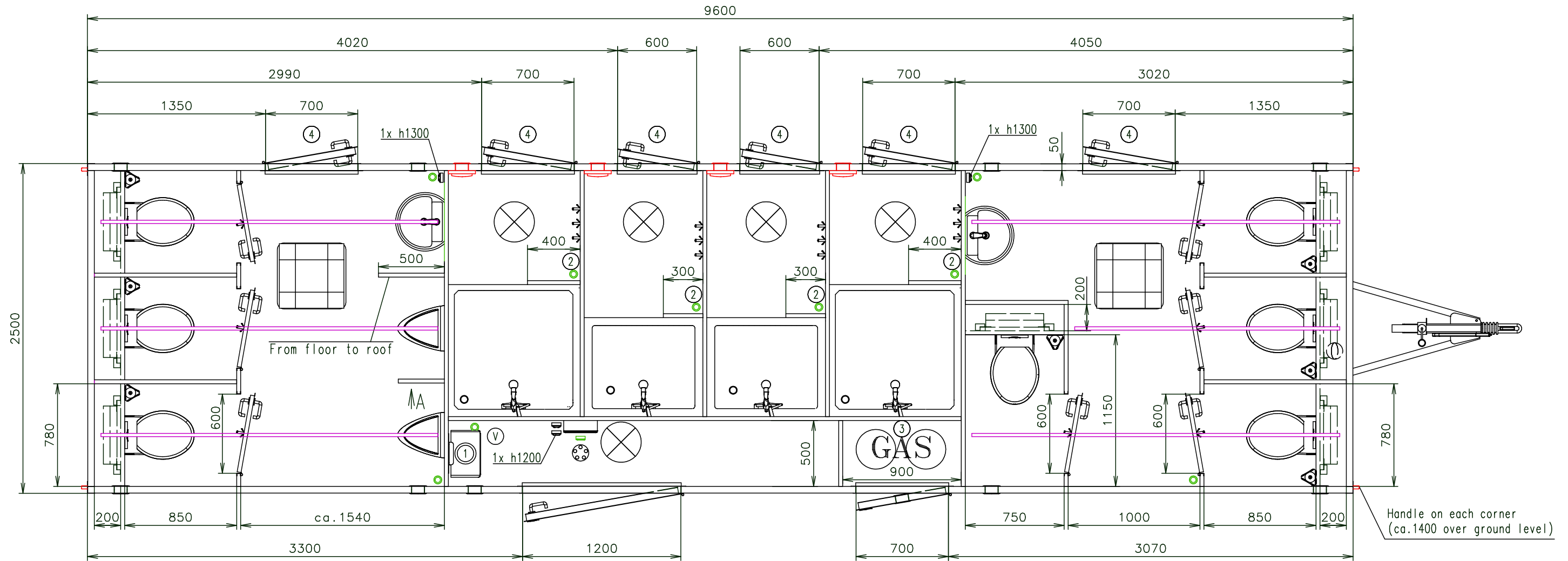

(Cabling and piping is not shown on the 3D views and drawings)

Water piping – inclined for discharging (won't be fully discharged)

External doors – without handles only preparing

Without stairs, heatings and toilet paper holders

Showers – waste piping – without siphones, only pipe directly under floor, not connected to main pipe – finished by customer

Notes:

| | | | |
|------------------|-----------|----------------------------------|----------|
| Interior height: | 2100 mm | Total weight: | 3000 kg |
| Color: | RAL 9010 | Tare weight-estimate: | 2600 kg |
| Floor: | PVC black | Centre of wheels from rear side: | 4800 mm |
| Date: | 5.2.2018 | Wheels: | 185 R14C |

EUROWAGON

Drawing number:

2863-96-2_1/2

| Connection hoses and cables | |
|-----------------------------|---|
| Water hose: | ✓ |
| Waste water hose: | ✗ |
| Electric cable: | ✓ |

Ⓧ Water connection 3/4" (through the floor)

Ⓧ Electric connection (through the floor) (230V-16A)

Ⓧ Effluent connection ø110 (under floor) - only from toilets, urinals and wash-basin

Ⓧ Power point

Ⓧ Light switch

Ⓧ Switch board (1200 over floor)

Ⓧ LED stripe (warm white)

Ⓧ Sensorlight

Ⓧ Electric ventilator 230V (with light)

Ⓧ Floor drain hole

Ⓧ Shower (900x750) Ravak Aneta

Ⓧ Shower (1000x1000)

Ⓧ Wash-basin Kolo (450x370) + standard water tap

Ⓧ Hanging toilet

Ⓧ Urinal - Uridan (waterless)

Ⓧ Roof window Dometic (400x400)

Ⓧ Ventilation ø120

Ⓧ Brush toilet

Ⓧ Clothes hanger

Ⓧ Mirror (600x600)

① Gas water heater - Rinnai Infinity

② Automatic coin machine for hot water in showers - customer completely supply

③ Gas regulator

④ Without stairs

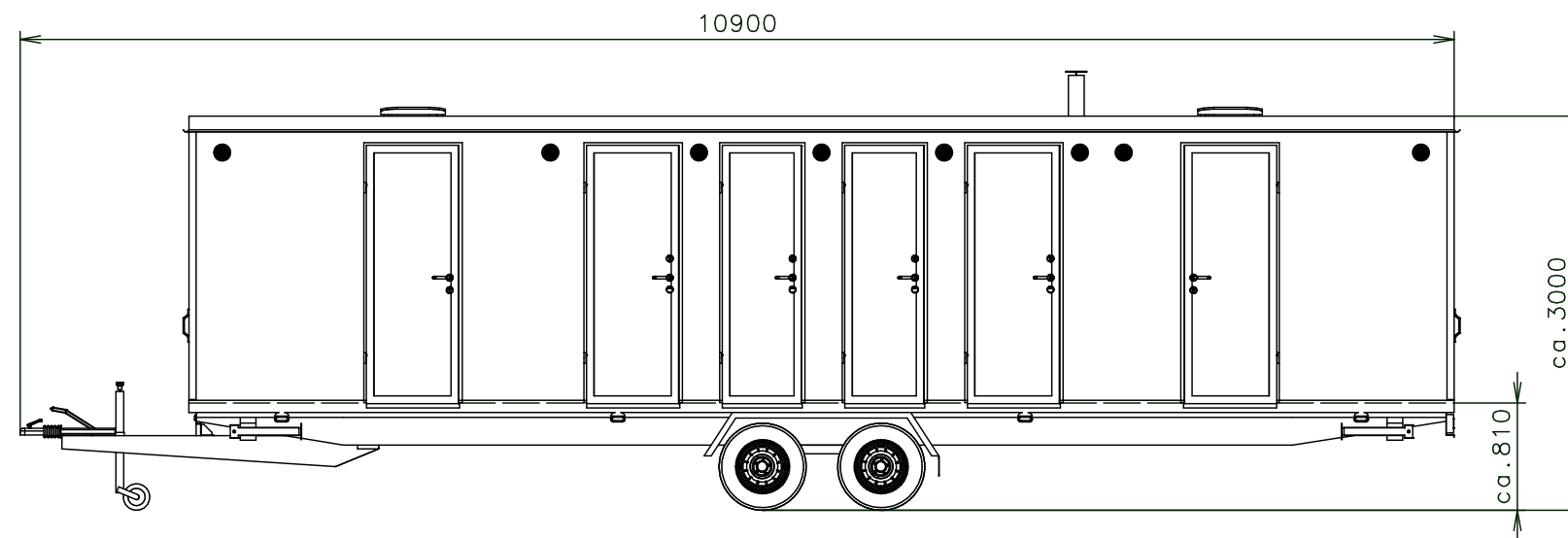

(Cabling and piping is not shown on the 3D views and drawings)

Water piping - inclined for discharging (won't be fully discharged)

External doors - without handles only preparing

Without stairs, heatings and toilet paper holders

Showers - waste piping - without siphones, only pipe directly under floor, not connected to main pipe - finished by customer

Notes:

| | | | |
|------------------|-----------|----------------------------------|----------|
| Interior height: | 2100 mm | Total weight: | 3000 kg |
| Color: | RAL 9010 | Tare weight-estimate: | 2600 kg |
| Floor: | PVC black | Centre of wheels from rear side: | 4800 mm |
| Date: | 5.2.2018 | Wheels: | 185 R14C |

EUROWAGON

Drawing number:

2863-96-2_2/2